

EMCO Transparent Liquid Level Gauges Series ET30 Pressure Rating: PN 160/900 lbs

Principle

EMCO liquid glass level gauges are designed for direct observation of liquid levels in vessels, drums and other tanks where direct dependable observation is required for pressure ratings up to PN 160, 900 lbs

Application

EMCO transparent liquid level gauges are suitable for observation of - the colour of the liquid, interface between two liquids, and in conjunction with protective shields - water/steam, caustic, hydrofluoric acid and other media erosive and corrosive to glass. The liquid level indication can be improved for difficult to see liquids by applying an Illuminator.

Material is sourced from approved manufacturers to meet specific customer requirements and general material standards like NORSOK M-630, Quality Track Record (QTR) in accordance with M-650 can be provided

Construction

The EMCO transparent liquid level gauge type ET30 consists of 4 main parts: The process chamber, two glasses and two covers. the size of the chamber is 100 x 40 mm, the cover is 80 x 40 mm.

The liquid chamber and covers are made from solid bar stock.

The cover may be selected in a less exotic material than the process chamber.

The gauge glass is toughened borosilicate glass with high resistance to thermal shock.

The glasses have narrow manufacturing tolerances with high degree of flatness.

The glasses are delivered in 9 lengths.

The EMCO transparent liquid level gauges consist of one solid process chamber and one or more sections.

When more than one section is required there is a blind distance between the sections.

The length of this blind distance is 40 mm.

If full visual liquid level is required sections are mounted off set. Series ET31

The off set type is also recommended for steam drum level indication.

If welding is part of the delivery this is performed in house using certified WPQR and WPS.



2 x size 5 with illuminator

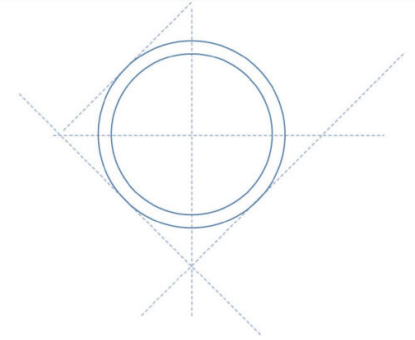

Pressure Equipment Directive 97/23 EC

The EMCO liquid level gauges are fully in compliance PED 97/23 EC
The volume and the small sized pipes mean that the EMCO glass level gauge falls under Article 3, Paragraph 3, also known as SEP (Sound Engineering Practice) therefore, the level gauges shall not and must not be CE marked

Certification

EMCO Controls is certified to ISO 9001-2008 and EN-3834-2

Technical Data

Sizes	: visual length from 95 to 2480 mm.
Material, chamber	: carbon steel A105 or A350 LF2, A182 F5 or F9, AISI 316, 22Cr duplex, 25Cr duplex, 6Mo, Titanium, Hastelloy B and C, Monel 400.
Material, gasket	: general purpose fibre, Graphoil, pure PTFE, glass fibre reinforced PTFE.
Material, glass	: toughened borosilicate glass to DIN 7080/7081, other standards on request.
Pressure	: max 160 bar, consult pressure/temperature tables for selected material
Temperature	: max 400 °C., consult pressure/temperature tables for selected material
Connection style	: threaded, NPT or BSP, weld ends or flanges to ANSI/ASME, DIN or EN1092-1 standards.
Connection sizes	: ½", ¾",
Connection positions	: top and bottom, left or right hand side,

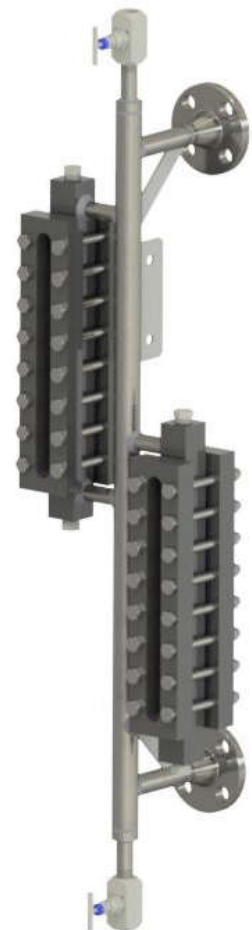

Type ET31
Off-set mounting

0-02-015-0e

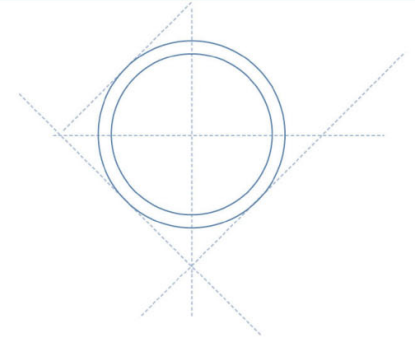

Accessories

Illuminators for hazardous areas with ATEX Ex approvals or non- hazardous areas.
Illuminator is recommended for difficult to see liquids

Straight or off set shut off valves with ball check if required, drain and vent valves.

Protective shields for glasses for corrosion and erosion protection.

Heating or cooling tubes for maintaining a desired fluid temperature

Non-frosting transparent acrylic resin plate for temperature below 0°C.

Plate height:

-49 to 0°C: 80 mm, -99 to -50°C: 150 mm, -100°C and below: 200 mm

Gauge scales with graduation in percentage or physical units

For remote indication EMCO liquid level gauges can be supplied with level transmitter integrated
In the level gauge or in a separate chamber connected to the level gauge.

The measuring principle is guided wave.

The output signal is 4 – 20 mA and HART, other communication protocols on request.

Pos 1	chamber	
Pos 2	cover	
Pos 3	studs	
Pos 4	nut	
Pos 5	glass	recommended spare part
Pos 6	gaskets	recommended spare part
Pos 7	illuminator	
Pos 8	seal	

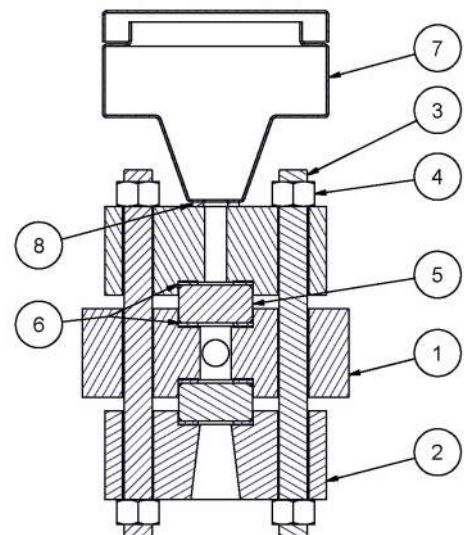

0-02-015-0e

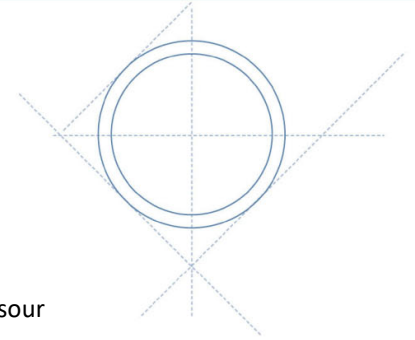

Documentation

Dimensional drawing, material certificate, QTR, pressure test certificate, Certificate for sour service to NACE MR-01-75/ISO 15156, PMI test, NDT of welding (if any) to EN, ASME or NORSOK M-601 standards.

Dimensions

	Visual length	length of chamber	length of glass
1	95 mm	140 mm	115 mm
2	120 mm	165 mm	140 mm
3	145 mm	190 mm	165 mm
4	170 mm	215 mm	190 mm
5	200 mm	245 mm	220 mm
6	230 mm	275 mm	250 mm
7	260 mm	305 mm	280 mm
8	300 mm	345 mm	320 mm
9	320 mm	365 mm	340 mm
2x3	330 mm	375 mm	
2x4	380 mm	425 mm	
2x5	440 mm	485 mm	
2x6	500 mm	545 mm	
2x7	560mm	605 mm	
2x8	640 mm	685 mm	
2x9	680 mm	725 mm	
3x6	770 mm	815 mm	
3x7	860 mm	905 mm	
3x8	980 mm	1025 mm	
3x9	1040 mm	1085 mm	
4x7	1160 mm	1205 mm	
4x8	1320 mm	1365 mm	
4x9	1400 mm	1445 mm	
5x7	1460 mm	1505 mm	
5x8	1660 mm	1605 mm	
5x9	1760 mm	1805 mm	
6x8	2000 mm	2045 mm	
6x9	2120 mm	2165 mm	
7x8	2340 mm	2385 mm	
7x9	2480 mm	2525 mm	

0-02-015-0e